

KIT FORNO JADE

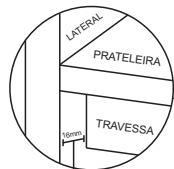

FIXAR TRAVESSA COM RECUO DE 16mm

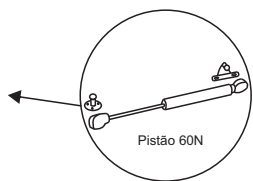
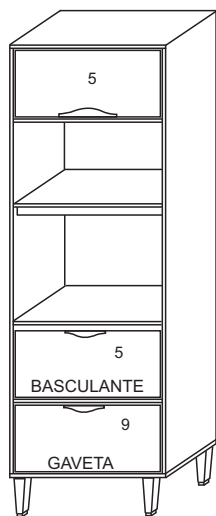
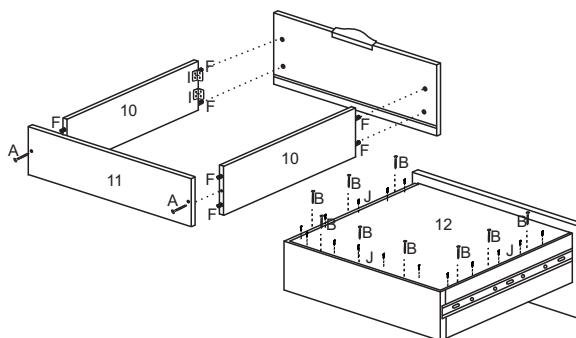
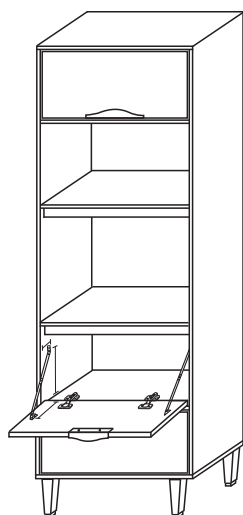
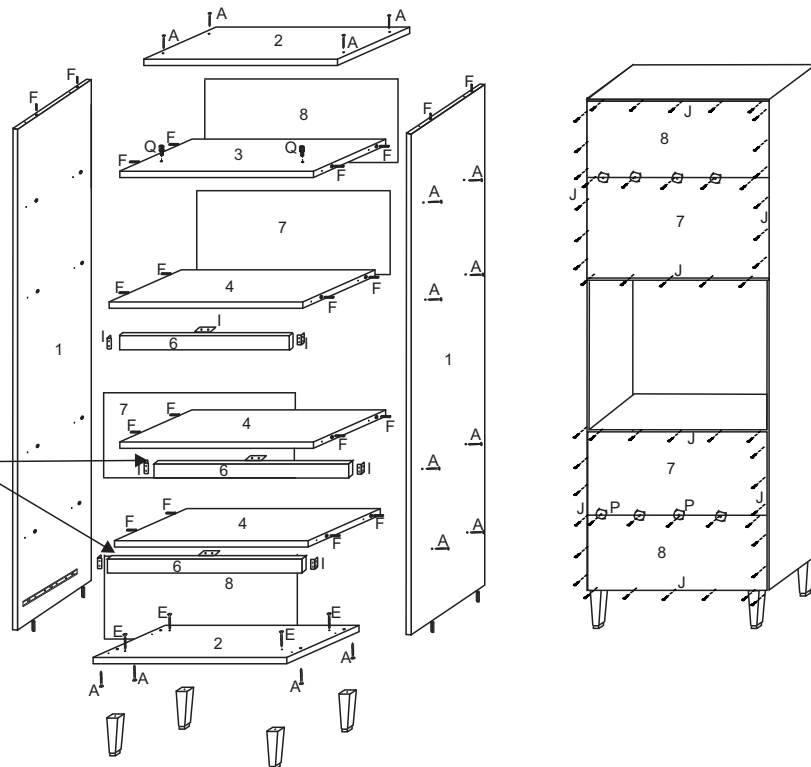

FERRAGENS

| | | |
|---|--|------------------------|
| A | | Parafuso 3,5 x 40 |
| B | | Parafuso 3,5x25 |
| C | | Parafuso 3,5x14 |
| D | | Parafuso 6,0x45 |
| E | | Parafuso 5,0 x 40 |
| F | | Cavilha 6,0x30 |
| G | | Bucha 8mm |
| H | | Cantoneira fixar aéreo |
| I | | Cantoneira 4 furos |
| J | | Prego 10x10 |
| L | | Dobradiça Caneco |
| M | | Puxador |
| N | | Pé |
| O | | Corrediça telescópica |
| P | | Fixador Costas |
| Q | | Suporte pino 6 x 8 |
| R | | Pistão 60 N |
| S | | Articulador |

| 5226 | | KIT FORNO | | | | |
|------|--------|--------------------------|------|------|-----|-------|
| N° | Ref | Item | comp | larg | esp | Quant |
| 1 | LA5201 | Lateral direita/esquerda | 2000 | 495 | 15 | 2 |
| 2 | BT5201 | Base/Tampo | 700 | 495 | 15 | 2 |
| 3 | BS5200 | Base superior | 670 | 495 | 15 | 1 |
| 4 | DI5201 | Divisão | 670 | 495 | 15 | 3 |
| 5 | PB5200 | Porta Basculante | 326 | 665 | 15 | 2 |
| 6 | TR5200 | Travessa | 670 | 54 | 15 | 3 |
| 7 | CO5201 | Costas maior | 370 | 695 | 2,8 | 2 |
| 8 | CO5202 | Costas | 350 | 695 | 2,8 | 2 |
| 9 | FG5200 | Frente gav | 326 | 665 | 15 | 1 |
| 10 | LG5200 | Lateral gavetão | 180 | 385 | 15 | 2 |
| 11 | TG5200 | Travessa gav | 180 | 646 | 15 | 1 |
| 12 | CG5200 | costas gaveta | 646 | 405 | 2,8 | 1 |