

BALCÃO 70 P/FORNO EVOLUTION

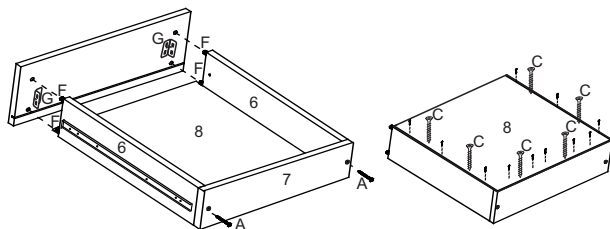
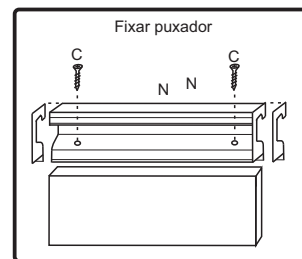
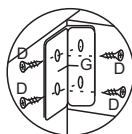
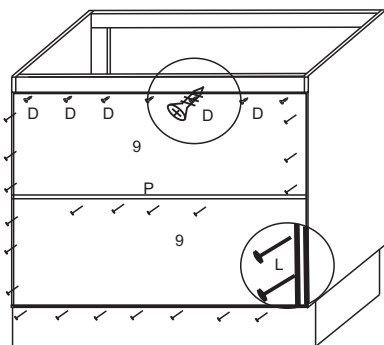
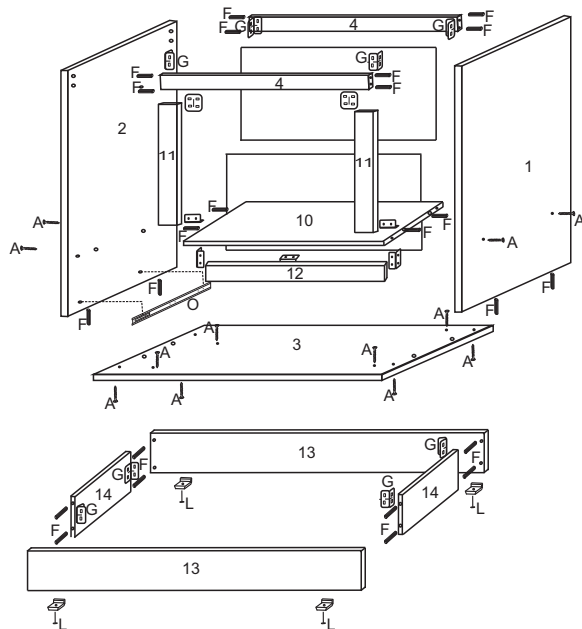
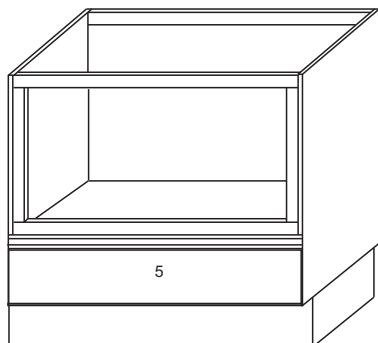

FERRAGENS

A		Parafuso 3,5 x 40 (Estrutura balcão)
B		Parafuso 4,0x45 (Estrutura aereo)
C		Parafuso 3,0 x 20 (Puxador)
D		Parafuso 3,5x14 (Dobrad, corred, canton, cost)
E		Parafuso 6,0x45 (Parede)
F		Cavilha 6,0x30 (Estrutura)
G		Cantoneira 17x17x46 (Gaveta, travessa, filete)
H		Bucha 8mm (Parede)
I		Cantoneira fixar aéreos
J		Cantoneira 3 furos (Divisão)
L		Prego 10x10 (Costas)
M		Dobradiça c/amortecedor
N		Puxador gola alumínio
O		Corrediça telescópica 400mm
P		Perfil H (Costas)
Q		Sapata deslizante (Rodapé)

BALCÃO P /FORNO 700X865X510							
N°	Ref.	Item	comp	larg	esp	Quant	
1	IA8024	Lateral direita 2 gav	700	495	15	1	
2	IA8025	Lateral esquerda 2 gav	700	495	15	1	
3	BA8024	Ba e Balcão	700	495	15	1	
4	TR8024	Travessa Balcão	670	54	15	2	
5	FR8425	Frente Gav	136	690	15	1	
6	LG8021	Lateral gaveta	90	385	15	2	
7	TG8026	Travessa gaveta	90	645	15	1	
8	CG8024	Costas gaveta	405	645	2,8	1	
9	CO8005	Costa	338	695	2,8	2	
10	DI8022	Divisão	670	480	15	1	
11	VI8023	Vista vertical	442	54	15	2	
12	VI8021	Vista horizontal	670	54	15	1	
13	RO8004	Rodapé	700	150	15	2	
14	RL8000	Rodapé Lateral	400	150	15	2	